

# Installation Instruction

## Linear Highbay

Applicable models:  
**SSL-LHB6**

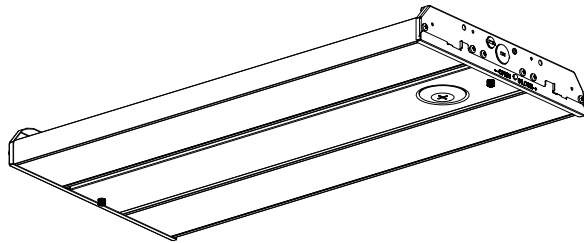

### SAFETY INFORMATION

Please read and understand this entire manual before attempting to assemble, operate or install the product. Failure to do so could lead to electric shock, fire or other injuries that could be hazardous or even fatal.

- Be sure the electricity to the wires you are working on is shut off. Either remove the fuse or turn off the circuit breaker.
- Changes or modifications not expressly approved by the party responsible for compliance could void the user's authority to operate the equipment.
- This product must be installed in accordance with local, state and national electrical codes.
- Installation work shall be completed by a licensed installer that is familiar with the construction and operations of the product.

#### CAUTION:

- This product contains 1-10v low-voltage DC dimming lines, connect the purple and pink wires only to a suitable low voltage dimming system. Connecting these dimming leads to AC line voltage will damage the driver and cause the unit to fail.

### SAFETY INFORMATION

#### NOTICE

This device complies with Part 15 of the FCC Rules. Operation is subject to the following two conditions: (1) This device may not cause harmful interference, and (2) this device must accept any interference received, including interference that may cause undesired operation.

This equipment has been tested and found to comply with the limits for a Class B digital device, pursuant to part 15 of the FCC Rules. These limits are designed to provide reasonable protection against harmful interference in a residential installation. This equipment generates, uses and can radiate radio frequency energy and, if not installed and used in accordance with the instructions, may cause harmful interference to radio or television reception, which can be determined by turning the equipment the equipment off and on. The user is encouraged to try to correct the interference by one or more of the following measures:

- Reorient or relocate the receiving antenna.
- Increase the separation between the equipment and the receiver.
- Connect the equipment into an outlet on a circuit different from that to which the receiver is connected.
- Consult the dealer or an experienced radio/TV technician for help.

### INSTALLATION INSTRUCTIONS

Make Sure the **POWER IS TURNED OFF** at the source to the location at which you are installing the product.

1. Hang the fixture securely with the sling as shown in the picture Fig1, and make sure the sling latch is locked.

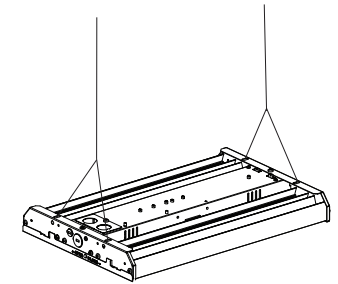
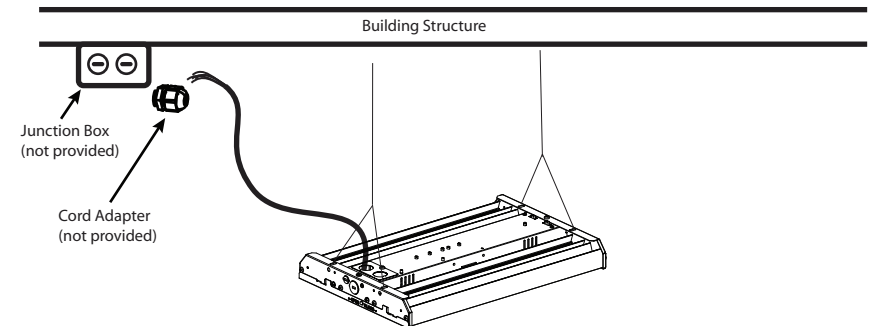

Fig 1.

2. Route the input cord into building junction box using appropriate adapters as required (not provided). Connect input wires as indicated in the following wiring diagram.



## INSTALLATION INSTRUCTIONS

- Slide the switches to set the desired wattage and color temperature

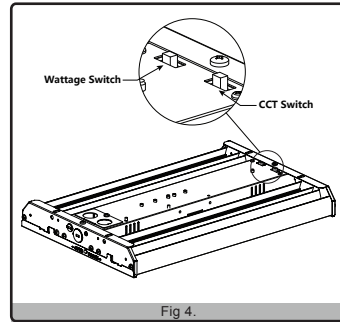

## SENSOR INSTALLATION

- Unscrew the plastic cover, then screw the sensor in.

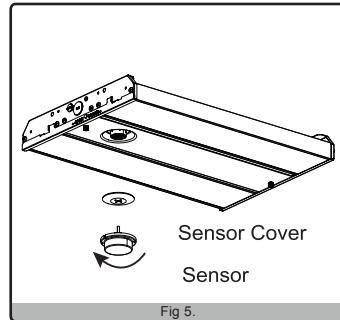

## WIRING DIAGRAM

### Input connections

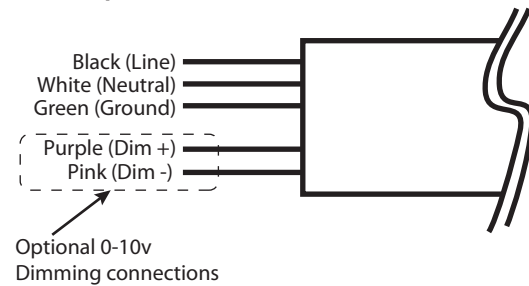

## REPLACE THE DIFFUSER TO ADJUST THE BEAM ANGLE

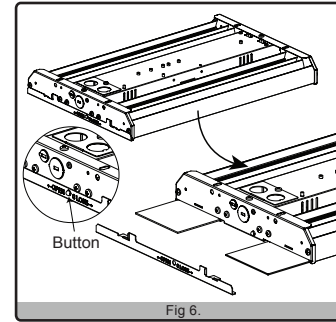

- Push the middle button showed in the illustration and slide the bar to the left then the bar will pop out.
- Draw out the existing diffuser and replace it with desired diffuser.
- After all set, re-assembly the bar back to the fixture

## MAINTENANCE AND CARE

Clean with a mild, non-abrasive glass cleaner and soft cloth. Do NOT use solvents or cleaners containing abrasive agents. When cleaning the fixture, make sure the power is turned off, and any liquid spray should be applied to the cleaning cloth and not sprayed directly onto the fixture itself.

## TROUBLESHOOTING

Problem	Possible Solution	Corrective Action
Fixture does not light.	<ol style="list-style-type: none"> <li>Power is off.</li> <li>Incorrect wire connection.</li> <li>Defective wall switch.</li> </ol>	<ol style="list-style-type: none"> <li>Check circuit breaker or wall switch.</li> <li>Check wire splices.</li> <li>Replace switch.</li> </ol>
Circuit breaker trips when light is turned on.	Crossed wires or power wire is grounded out.	Verify wires are correctly connected.

## WARRANTY

This fixture is warranted to perform free from defects for five (5) years.